

MAH8800 & MAH1100 Series Pedestal Enclosures

NEW!

The new Channell MAH Profile Series Pedestal Enclosures are the industry's most cost-effective enclosure system. Precision engineered, they are manufactured of high performance thermoplastic material for the utmost protection of equipment and maximum service life.

The MAH Profile Series Enclosure is the "lowest first cost" value in the industry. It is supplied with a full complement of standard features, which includes Self-Lock® security covers and factory installed bracketry, enhancing the value of this innovative product. In addition, the unique design of the enclosure provides an attractive profile for residential installations.

Applications

These free-breathing pedestals are designed for use in buried and underground cable plant installations for distribution tap and splicing applications.

Features

- Complete 360° working access
- Non-corrosive, lightweight and rugged
- Universal terminal block mounting plate
- 2-point Self-Lock® security
- Designed to the requirements of Telcordia Spec GR-13-CORE
- RUS listed
- Winter drop access door and drop wire channel standard



MAH8815 Shown



MAH8800 shown with splice ladder
loop bundle support installed



MAH8800 shown with
fiber tap installed

Specifications

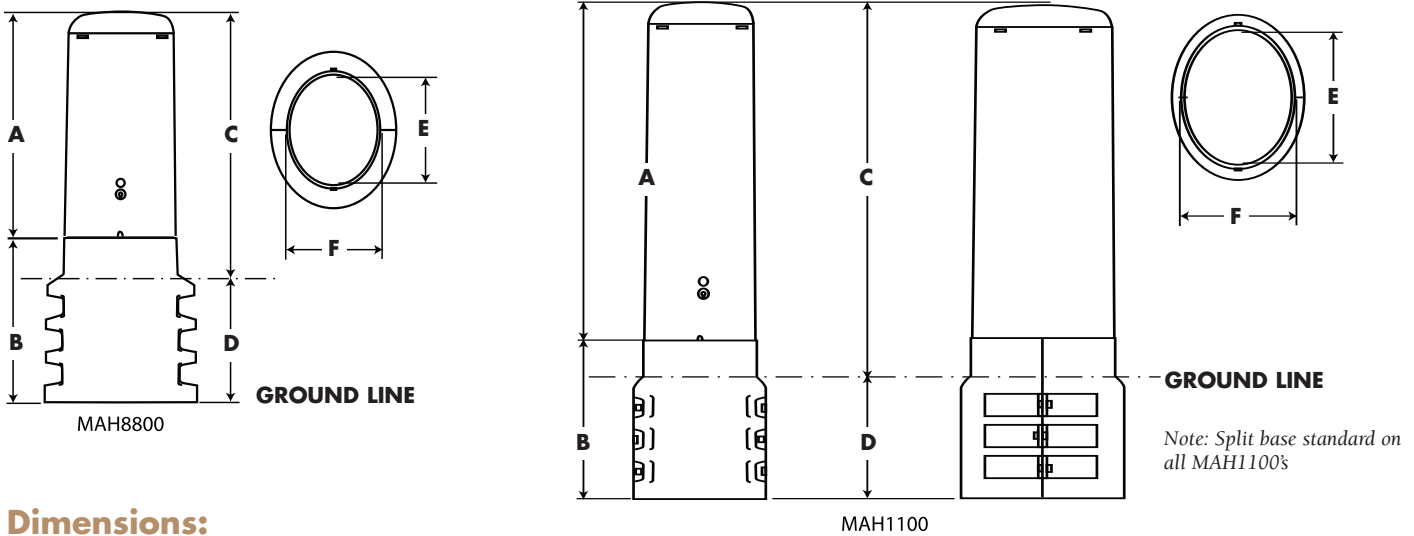

Dimensions:

	A	B	C	D	E	F
MAH8815	15.0" 381.0mm	13.0" 330.2mm	17.5" 444.5mm	10.0" 254.0mm	8.0" 203.2mm	6.0" 152.4mm
MAH1100	27.5" 698.5mm	13.0" 330.2mm	30.2" 774.7mm	10.0" 254.0mm	10.875" 276.2mm	8.25" 209.55mm

Model	Conduit Capacity			Innerduct Capacity			
	4"	3"	2"	1"	1-1/4"	1-1/2"	2"
8800	2	2	8	28	18	11	7
1100	3	6	13	49	32	25	14

Ordering Information

	MAH	XX	XX	CX	BX	LH1	AXX
Multiple Access Housing	_____						
Diameter	_____						
88 – 8" (203.2mm) diameter oval	_____						
11 – 11" (279.4mm) diameter oval	_____						
Length	_____						
15 – MAH8800 15" (381mm) height (Note: 26" (660.4mm) height also available)	_____						
00 – MAH1100 Standard 27.5" (698.5 mm)	_____						
Color	_____						
C1 – Light Green	_____						
C2 – Beige	_____						
C3 – Dark Green	_____						
C4 – Brown	_____						
C5 – Gray	_____						
Bracket Option	_____						
BX –	_____						
Locking Option	_____						
LX –	_____						
Option	_____						
A01 – Condensation Vented	_____						
A02 – Non-Vented Bell Jar Cover	_____						



CHANNELL

USA: Channell Commercial Corporation, Temecula, CA • Tel. 800.423.1863 • Fax. 951.296.2322

CANADA: Channell Canada, Inc. • Tel. 905.565.1700 • Fax. 905.565.8080

EUROPE, MIDDLE EAST, AFRICA: Channell Ltd., London, UK • Tel. 44.1689.871522 • Fax 44.1689.833428

AUSTRALIA, ASIA, PACIFIC RIM: Channell Pty. Ltd., Sydney, Australia • Tel. 61.2.9738.8277 • Fax. 61.2.9738.9763

WORLDWIDE HEADQUARTERS: Channell Commercial Corporation • 951.719.2600 • 26040 Ynez Road • P.O. Box 9022 • Temecula, CA 92589-9022, USA

All specifications subject to change without notice.

www.channellcomm.com

Printed in U.S.A. CH05-158 1105TA5M

Self-Lock and Mini-Rocker are registered trademarks of Channell Commercial Corporation.