



CHANNELL

Where The Industry Connects.®

ORDERING GUIDE

NEW!

MAH Profile Series™ Pedestal Enclosures

The new Channell MAH Profile Series Pedestal Enclosures are the industry's most cost-effective thermoplastic enclosure system.

Precision engineered, the MAH Profile Series Enclosures are manufactured of high performance, outside plant rated thermoplastic material for the utmost protection of equipment and maximum service life.

The MAH Profile Series Enclosure is the “lowest first cost” value in the industry. It is supplied with a full complement of standard features, which includes Self-Lock® security covers and factory installed bracketry, enhancing the value of this innovative product. In addition, the unique design of the MAH Profile Series Enclosure provides an attractive profile for residential installations.

For lowest total cost deployment, Channell will provide the MAH Profile Series Enclosures with either fiber optic or copper broadband termination and cable management equipment. This cost effective package can be installed directly as a single package, minimizing inventory, installation and material handling costs.



MAH8800 Shown

Applications

These thermoplastic pedestals are designed for use in buried and underground cable plant installations for distribution terminal and splicing applications, both copper and FTTP networks.

Features

- Complete 360° working access
- Non-corrosive, lightweight and rugged
- Universal terminal block mounting plate
- Self-Lock® security hex lock for access with 216B can wrench/NSQ2000 tool
- Designed to the requirements of Telcordia Spec GR-13-CORE
- RUS listed
- Winter drop access door and drop wire channel
- High rib base for stable mounting



*MAH8800 shown with
25-Pair Mini-Rocker®
Terminal installed*

*MAH8800 shown with
fiber tap installed*

*MAH8800
Typical Installation*

Specifications

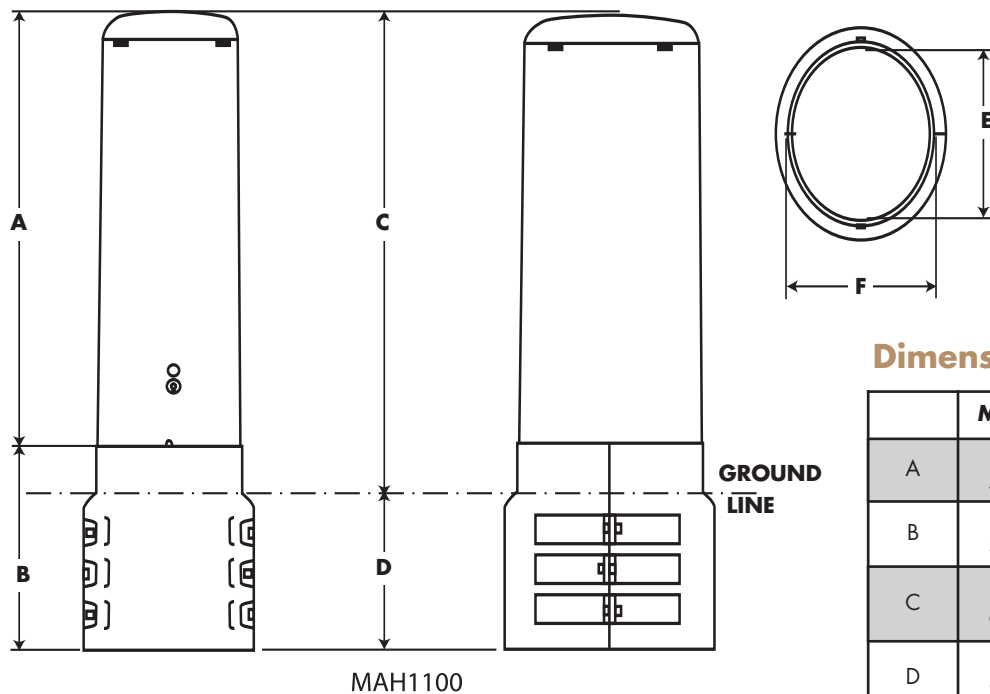
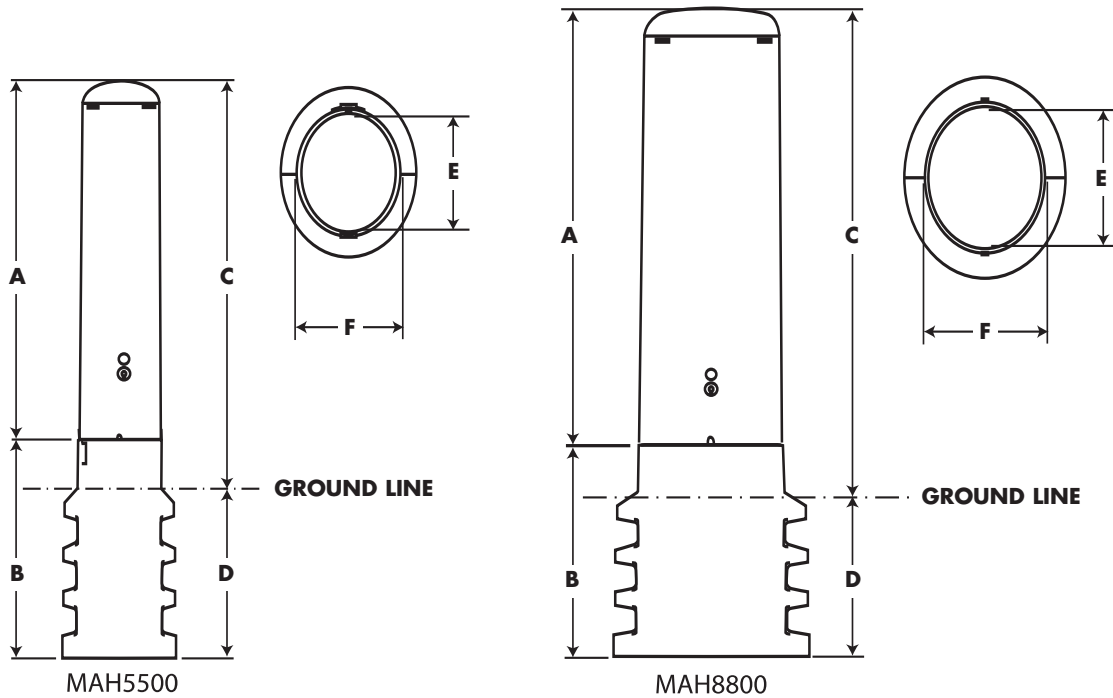

Note: Split base standard on all MAH1100's

Dimensions:

	MAH5500	MAH8800	MAH1100
A	21.5" 546.1mm	27.5" 698.5mm	27.5" 698.5mm
B	13.0" 330.2mm	13.0" 330.2mm	13.0" 330.2mm
C	24.2" 614.7mm	30.2" 774.7mm	30.2" 774.7mm
D	10.0" 254.0mm	10.0" 254.0mm	10.0" 254.0mm
E	5.5" 139.7mm	7.75" 196.85mm	10.5" 266.7mm
F	4.5" 114.3mm	6" 152.4mm	8.25" 209.55mm

Conduit Capacity:

Pedestal	4" PVC	3" PVC	2" PVC	1" Innerduct	1-1/4" Innerduct	1-1/2" Innerduct	2" Innerduct
5500	1" (25.4mm)	2" (50.8mm)	3" (76.2mm)	16" (406.4mm)	10" (254mm)	7" (177.8mm)	4" (101.6mm)
8800	2" (50.8mm)	2" (50.8mm)	8" (203.2mm)	28" (711.2mm)	18" (457.2mm)	11" (279.4mm)	7" (177.8mm)
1100	3" (76.2mm)	6 (152.4mm)	13" (330.2mm)	49" (1244.6mm)	32" (812.8mm)	25" (635mm)	14" (355.6mm)

Ordering Information

	<u>MAH</u>	<u>XX00</u>	<u>CX</u>	<u>BX</u>	<u>LH1</u>	<u>AXX</u>
Multiple Access Housing						
Diameter						
55 – 5" (127mm) diameter oval						
88 – 8" (203.2mm) diameter oval						
11 – 11" (279.4mm) diameter oval						
Color						
C1 – Light Green						
C2 – Beige						
C3 – Dark Green						
Bracket Option						
B1 – Universal mounting plate, copper wire management clips, bond bar assembly, loop bundle support						
B2 – Universal mounting plate for fiber terminal						
B3 – Splice ladder, loop bundle support						
B4 – Splice ladder, loop bundle support and bond bar assembly						
B7 – 25-Pair In-Line Mini-Rocker Terminal with 4-ft. aircore non-shielded stub						
B9 – 10-Pair In-Line Mini-Rocker Terminal with 4-ft. aircore non-shielded stub						
Locking Option						
LH1 –Self-Lock™ Locking System-- 216B Accessible						
Option						
A01 – Condensation Vented						
A02 – Non-Vented Bell Jar Cover						

Example: MAH8800C1B7LH1A01 – MAH88, light green, 25-pair In-Line Mini-Rocker® Terminal with 4-ft. aircore non-shielded stub, Self-Lock Locking System--216B Accessible, Condensation Vented



CHANNELL

USA: Channell Commercial Corporation, Temecula, CA • Tel.800.423.1863 • Fax.951.296.2322

CANADA: Channell Canada, Inc. • Tel. 905.565.1700 • Fax. 905.565.8080

EUROPE, MIDDLE EAST, AFRICA: Channell Ltd., London, UK • Tel. 44.1689.871522 • Fax 44.1689.833428

AUSTRALIA, ASIA, PACIFIC RIM: Channell Pty. Ltd., Sydney, Australia • Tel.61.2.9738.8277 • Fax.61.2.9738.9763

WORLDWIDE HEADQUARTERS: Channell Commercial Corporation • 951.719.2600 • 26040 Ynez Road • P.O. Box 9022 • Temecula, CA 92589-9022, USA

All specifications subject to change without notice.

www.channellcomm.com

Printed in U.S.A. CH05-100 0105TA5M

Self-Lock and Mini-Rocker are registered trademarks of Channell Commercial Corporation.